



GPON OLT Products User Manual

P1201-08

---Device Install Guide

Version: V1.0

© COPYRIGHT & TRADEMARKS

Specifications are subject to change without notice.  tp-link is a registered trademark of TP-Link Technologies Co., Ltd. Other brands and product names are trademarks or registered trademarks of their respective holders.

No part of the specifications may be reproduced in any form or by any means or used to make any derivative such as translation, transformation, or adaptation without permission from TP-Link Technologies Co., Ltd. Copyright © 2018 TP-Link Technologies Co., Ltd. All rights reserved.

About This Manual

This manual is applicable to P1201-08 GPON OLT products device install guide, Is the user to quickly and easily install GPON OLT equipment should read the information before guidelines.

The related documents for GPON OLT device are:

《P1201-08 OLT User Manual-Configuration Guide》

《P1201-08 OLT User Manual-Command Line Operation》

《P1201-08 OLT User Manual-EMS Software Part》

Contents

1	Instruction.....	1
	Revision History	1
2	Pre-Installation Preparation	1
2.1	Appearance and Interface	1
2.2	Power Requirement	3
2.3	Equipment Ground	3
2.4	Place Design Requirements	3
3	Hardware Installation.....	3
3.1	Open Box and Checkout.....	3
3.2	Pre-installation Preparation	3
3.3	OLT Installation.....	4
3.3.1	Plane Stack Installation	4
3.3.2	Rack Installation.....	4
3.4	Port and Connection	5
3.4.1	Uplink Port	5
3.4.1.1	Port Explanation.....	5
3.4.1.2	Port Connection.....	5
3.4.1.3	Method of Making Cable	6
3.4.2	PON Port Connection.....	6
3.4.3	Ground Cable Connection.....	6
3.4.4	Management Port Connection	7
3.4.5	Power Supply	8
3.4.5.1	Connecting the AC Power Cable.....	8
3.4.5.2	Connecting the DC Input Power Cable	8
3.5	OLT Working Status Checkout.....	9
3.5.1	Check Out Power Supply	9
3.5.2	Check Out OLT Working Status.....	9
3.5.3	Network Management Checkout.....	9
4	Default Configuration.....	10
4.1	Network Parameter Configuration	10
4.2	OLT Console Parameter Configuration	10
4.3	Default Username and Password.....	10
5	Appendix : OLT Specification.....	10

1 Instruction

Revision History

Date	Version	Description
2018-08-15	V1.0	GPON OLT (P1201-08) First Edition, Device Install Guide
2018-12-03	V1.0.1	Front interface and band rate information updated

2 Pre-Installation Preparation

2.1 Appearance and Interface

The P1201-08 is 1U high Pizza-Box, can be mounted into the standard 19” rack. Demission of machine frame: 440mm (L)*391mm(W)*44mm(H).

As shown below picture:

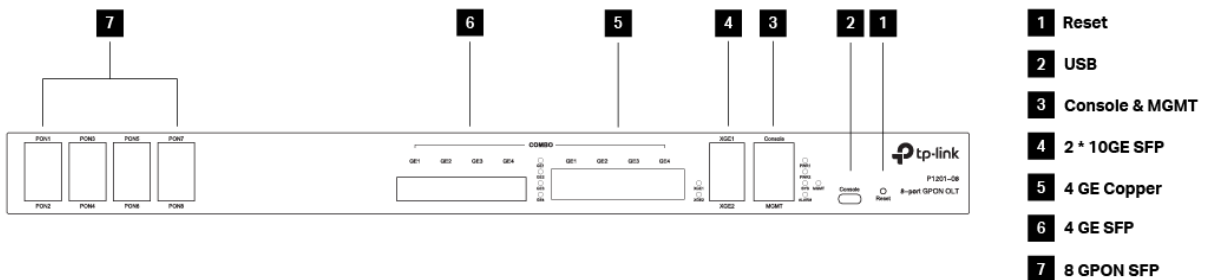

Front View of P1201-08

OLT Front Board Introduce:

Item		Specification
Uplink Port	COMBO port	4 10/100/1000M auto-negotiation Ethernet ports
		4 SFP interfaces
	10-Gigabit	2 SFP+ interfaces
PON Port	QTY	8
	Physical Interface	SFP Slots
	Connector Type	ITU-TG.984.2Class B+ or ITU-TG.984.2Class C+
	Max splitting ratio	1:128
Management Ports		1 100/1000BASE-Tx out-band Ethernet port 1 CONSOLE local management port
Reset		Reset OLT equipment

LED Status Introduce:

Type	Identification	Status	Indication
Power Supply Indicator	PWR n (n = 1/2)	Green , Always ON	Normal Power supply
		OFF	Power supply is unconnected or breaks down
System Status	SYS	Flash per second	System normally operate
Management Port	MGMT	Green , Always ON	Management port is connected
		OFF	Management port isn't connected
PON Port Indicator	P n (n=1/2/3/4/5/6/7/8)	Flash	There is communication data at GPON port(n)
		Green , Always ON	There are ONT register on OLT port (n) and the optical fiber link is normal.
		OFF	NO ONT link with the OLT port(n)
Uplink Port Indicator	GE n (n=1/2/3/4)	Flash	There is the communication data at the uplink port(n)
		Green , Always ON	The uplink port(n) is connected
		OFF	The uplink port(n) isn't connected
	XGEn (n=1/2)	Flash	There is the communication data at the 10GE uplink port(n)
		Green , Always ON	The 10GE uplink port(n) is connected
		OFF	The 10GE uplink port(n) isn't connected
Alarm	ALARM	Always ON	One fan doesn't work
		Slow Flash	Two fan doesn't work
		Fast Flash	More than three fan doesn't work
		OFF	All the fan work

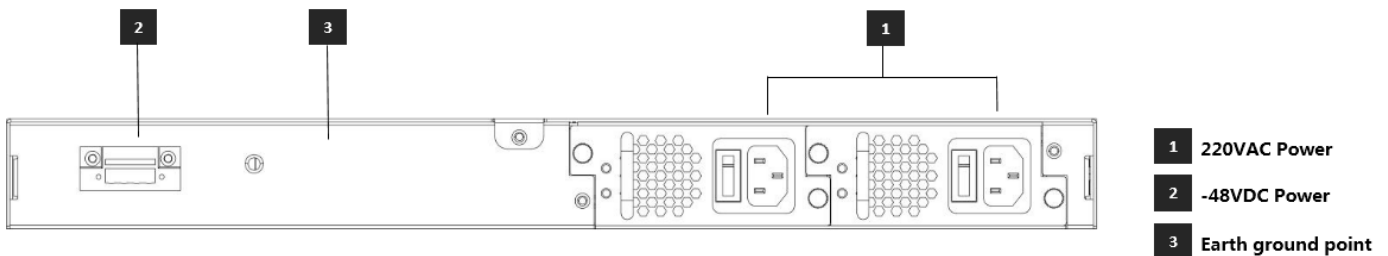

P1201-08 Rear View

Back View of P1201-08:

Item	Specification
Grounding Terminal	One, it's in the left of the front panel and is used to grounding for machine frame
Power Module	Support Pluggable type two power module. You can chose AC or DC power supply, optional

2.2 Power Requirement

The input voltage must be stable, no EMI noise and distortion.

When use DC power supply, the input voltage is -48VDC, the allowed range is -36 ~ -72 VDC.

When use AC power supply, the input voltage is 110/220VAC, the allowed range is 90 ~ 264VAC.

Note: Follow all security specification and the rule about the electricity in the locality or the building. All power supply must be legal.

2.3 Equipment Ground

The grounding body must be configured in the machine room, the grounding resistance value is less than 1Ω. It can be realize by layout the anti-static copper nose.

2.4 Place Design Requirements

The environment of the equipment operation has very big effect on its long-term reliable operation .Room design requests to up to the following standards:

- The device allows room temperature is 0 °C ~ 40 °C. To ensure that equipment works in the normal temperature environment (25 °C or so), should try to make the equipment away from the main heat source (such as power supply, etc.), if the environment temperature is higher than 40 °C, should try to improve the ventilated condition of the room, such as install fan in the frame or air conditioning in the room. The ventilation pipe in the room should be swept clean and ventilated, etc.;
- There must be the good cable wiring and go line space in the room. Cable and optical cable wiring (including fiber splicing work) are already in place.
- The related humidity 10% ~95%, No condensation, no frost;
- The dust particles density with more than 5μm in diameter $\leq 3.0 \times 10^4/m^3$; Dust particles is a non-conductive, the non-magnetic and the non-corrosive;

3 Hardware Installation

3.1 Open Box and Checkout

According to the packing list or supply contract, check and verify the goods, if any component is loss, wrong or damaged, please contact with your customer manager.

The list includes the following content normally:

- 1 OLT Machine(1 Pcs)
- SFP modules are ordered according to user requirement
- AC power line or DC power line according to user requirement

3.2 Pre-installation Preparation

Verify the following working environment and installation requirements

1 Power Supply Requirement:

- DC power supply: -48V DC, the allowed range:-36VDC~ -72 VDC
 - AC power supply: 110/220V AC, the allowed range: 90 ~ 264VAC
- 2 The equipment should be equipped in the dry, cool place, at least have 10 centimeters at both sides for the ventilation space.
 - 3 Avoid the direct light, far away from the heat source or the place with the stronger electromagnetic interference
 - 4 If want to install OLT inside the rack, ensure that have the necessary mounting screws and nuts and necessary tools.
 - 5 Check the required cable and connectors for installation
 - 6 In the system management, need connect the following equipment with OLT:
 - A management platform, such as PC
 - RJ45/DB9 RS232 Console line

3.3 OLT Installation

OLT can be put in the bigger horizontal surface or within the standard EIA 19 " rack.

3.3.1 Plane Stack Installation

Step I: Pre-Installation Validation

- Ensure the worktable is strong enough to support the weight of the device and cables.
- Ensure no obstacles on the worktable and the surroundings affecting the installation of the device exist.
- Prepare the OLT device to be installed and move the device to the place where is near the work table and facilitates the handling.

Step II: Lift the OLT device and slowly move to the front of the worktable.

Step III: Move the OLT device to the location slightly higher than the worktable and then place the OLT device to the specified location on the worktable.

3.3.2 Rack Installation

OLT equipment can be installed inside 19" rack which is compliance with ETSI standard. OLT rack diagram as shown in below.

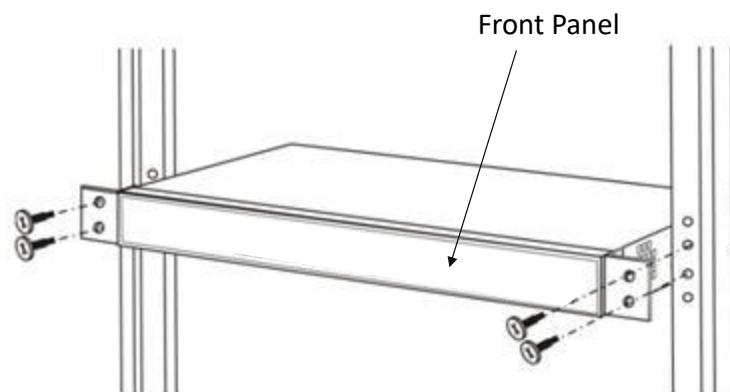

The installation process is as follows:

Step I: Pre-Installation Validation

- Ensure the cabinet is fixed and the installation location of the OLT device in the cabinet is

well arranged, and no obstacles inside the cabinet and the surroundings affecting the installation of the device exist.

- Prepare the OLT device to be installed and move the device to the place where is near the cabinet and facilitates the handling.

Step II: Lift the OLT device and slowly move the device to the front of the cabinet.

Step III: Lift the OLT device to the location slightly higher than the tray or sideway of the cabinet, place the OLT device to the tray or sideway of the cabinet and then push it to the cabinet.

Step IV. Use screws to fix the suspension loops of the cabinet to the square holes of the 19-inch cabinet column and to fix the OLT device to the cabinet.

3.4 Port and Connection

The chapter describes the port and power supply connection situation in OLT system, mainly include the following parts:

- Uplink Port
- PON Port Connection
- Ground Cable Connection
- Management Port Connection

Please carefully read the following introduction before connecting each port of OLT:

3.4.1 Uplink Port

3.4.1.1 Port Explanation

OLT offers eight GE electrical port, eight GE SFP optical port and two 10 Gigabit port for uplink. Electrical port and optical port can combination at the sometime, you can use direct-through, cross cable or fiber connection of the OLT and uplink equipment.

SFP module can be the optical module or the electrical module, and follow standards below:

- 1000Base-LX (Long wave length)
- 1000Base-SX (Short wave length)
- 10/100/1000Base-TX (Electrical port)

When use the single mode optical fiber, the maximum transmission distance can be up to 10-40km; when use the multimode fiber, the maximum transmission distance is less than 500 meters.

Gigabit Ethernet uplink port supports the duplex mode and flow control auto negotiation.

But need note that the maximum length of the optical fiber is related with work mode of the optical fiber:

- Maximum length of 1000Base-LX fiber is depend on duplex mode
- Maximum length of 1000Base-SX fiber is the same in both full duplex and half duplex mode

3.4.1.2 Port Connection

There are two kinds of uplink network connection:

- Cable with RJ45 connectors at both sides
- Cable with LC connector at both sides

Decide the port type of OLT according to the port type of the uplink device (Switch or Route)

3.4.1.3 Method of Making Cable

If you use SFP optical module, cable specification: the optical cable with LC connector at both sides.

If you use GE copper interface, cable specification: Category 5 cable or Category5 super cable with RJ45 connector at both sides

The below the reference for making STP (Shielded Twisted-Pair) cable with RJ45connector at both sides



3.4.2 PON Port Connection

P1201-08 supports eight GPON SFP slots, every SFP GPON slots can mount a GPON SFP module and provides one PON port.

Caution: When insert into optical cable, please confirm the connector is inserted into the correct position, thus guarantee the good contract.

SFP PON slots installs standard ITU-TG.984.2Class B+ or ITU-TG.984.2Class C+OLT SFP .The OLT SFP interface is SC/PC. Please use the patch cord with SC/PC connector to connect between the OLT and the ODN networking.

3.4.3 Ground Cable Connection

Ensure the safety and reliable working of OLT. P1201-08 should be connected with the ground if necessary. Grounding screws are located in the rear panel. While connecting, you should use screwdriver to loosen the grounding screw first, then connect the ground cable, finally tighten the screws.

3.4.4 Management Port Connection

OLT P1201-08 equipment provides console interface (marked as “CONSOLE” RJ45 type port) and MGMT management internet access (marked as “MGMT” RJ45 type port).

Console access is really only required when initially configuring a device, or if remote access fails.

Console access requires:

- Console cable: RJ-45-to-DB-9 console cable
- Terminal emulation software: HyperTerminal

The cable is connected between the serial port of the host and the console port on the device. Most computers and notebooks no longer include built-in serial ports. If the host does not have a serial port, the USB port can be used to establish a console connection. A special USB-to-RS-232 compatible serial port adapter is required when using the USB port.

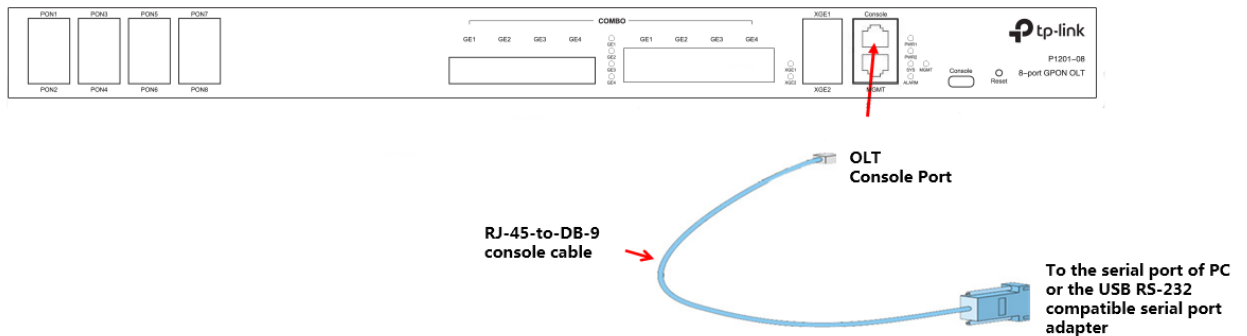

Port on Computer	Cable Required	Port on OLT
Serial Port	RJ-45 to DB-9 Console Cable	RJ-45 Console Port
USB Type-A Port	<ul style="list-style-type: none"> ● USB to RS-232 compatible serial port adapter (Adapter may require a software driver) ● RJ-45 to DB-9 Console Cable 	



RJ-45 to DB-9 Console Cable



USB to RS-232 compatible serial port adapter

When starting the management, please use straight and cross Ethernet cable, connecting “Console” management interface to network or managed PC.

MGMT access requires:

- RJ45 cable
- Terminal emulation software: HyperTerminal



3.4.5 Power Supply

3.4.5.1 Connecting the AC Power Cable

The two AC power supply units in the P1201-08 allow for 1 + 1 power redundancy. If one power supply unit fails, then the system will continue to operate using the remaining power supply unit. Additionally, to ensure true AC line input redundancy for the OLT, you should connect each AC power cable to a different AC power source. You can also connect an uninterruptible power supply (UPS) between each AC power source and the OLT to increase the availability of the OLT.

1. Get the supplied AC power cords from the OLT's shipment kit.
2. Connect one end of each AC power cord into the AC power inlet connectors located at the rear of the OLT.
3. Connect the other ends of the power cords into AC wall outlets. Connect each AC power cord to a different AC power source if you want AC line input power redundancy.

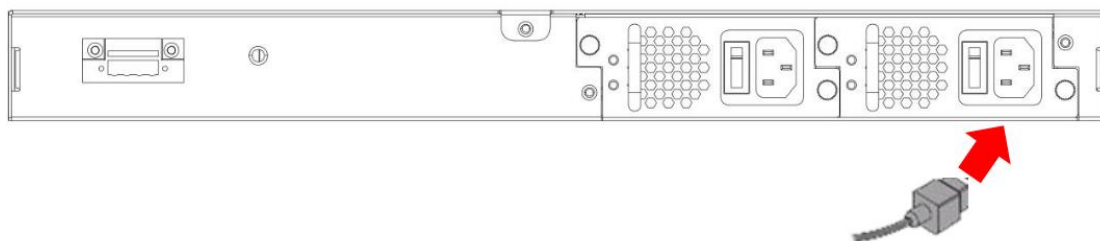

3.4.5.2 Connecting the DC Input Power Cable

1. Identify the parts that you will use to assemble the DC input power cable
The following DC connection cable is required to assemble one or more DC power input cables. These cables connect the -48V DC input source(s) to the power supply units.
2. Turn off power from the DC power source through the circuit breakers.
Caution - Do not proceed with these instructions until you have turned off the power from the DC power source through the circuit breakers.
3. Get a DC input plug from the ship kit.
4. Locate the four wires coming from the DC power source that will be used in the connection to your unit:
 - 48V: negative terminal
 - 48V: Return (positive terminal)
 - 48V: Earth ground

- Strip 5/16 inches (8mm) of insulation from each of the wires coming from the DC power source.

Do not strip more than 5/16 inches (8mm) from each wire. Doing so leaves uninsulated wire exposed from the DC connector after the assembly is complete.

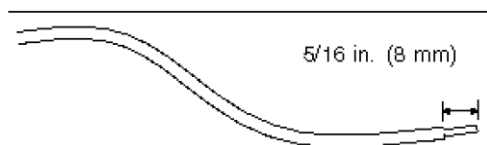

- Feed the exposed section of the appropriate wire into the rectangular plug hole in the DC input plug. Shows which wires should be inserted into each hole in the DC input plug.

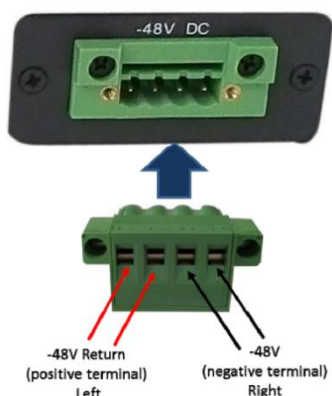

- Repeat Step 5 and Step 7 for the other two wires to complete the assembly of the DC input power cable.
- Connect the DC input power cables to the DC connectors.

3.5 OLT Working Status Checkout

3.5.1 Check Out Power Supply

Before you connect the power supply, double check the power supply if it is accord with the power supply requirements, If each module and card are installed correctly , If the equipment is in reliable grounding or not. After checking everything is OK, you can turn on the power supply sources.

3.5.2 Check Out OLT Working Status

Please check if the OLT's working status from following aspects:

- Check the power LED. The power LED will be on.
- The SYS LED will flash per second
- If the uplink equipment is connected to the uplink port, the relevant connection LED is on.

3.5.3 Network Management Checkout

Local Command Line Interface Management:

Use the RJ45/DB9 Serial Port cable (in package) to link management PC with P1201-08 CONSOLE or MGMT port. Management computer can access to OLT equipment from Super terminal interface of the PC for configuration.

※Please refer to relevant CLI user manual.

4 Default Configuration

4.1 Network Parameter Configuration

OLT out-band management port default IP address:

IP Address: 192.168.1.100

Subnet Mask: 255.255.255.0

Default Gateway: 192.168.1.1

4.2 OLT Console Parameter Configuration

Band Rate: 9600

Data Bit: 8

Parity Check: NO

Stop Bit: 1

Flow Control: NO

4.3 Default Username and Password

CLI command line default login username and password:

Username: root

Password: admin

5 Appendix : OLT Specification

Item		P1201-08
Management Rack	Type	1U 19-inch standard box
	Slot	2 power module slot
Uplink Port	COMBO port	4 10/100/1000M auto-negotiation Ethernet ports
	10-Gigabit	4 SFP interfaces 2 SFP+ interfaces
PON Port	Quantity	8
	Physical interface	SFP slot
	Interface type	ITU-TG.984.2 Class B+/Class C+
	Max splitting ratio	1:128
Management port		1 100/1000BASE-Tx out-band Ethernet port 1 CONSOLE local management port

PON port attribute	Transmission distance	20KM	
	Port rate	Downstream: 2.5Gbps	Upstream: 1.25Gbps
	Wavelength	Forwarding: 1490nm	Receiving: 1310nm
	Interface type	SC/UPC	
	Fiber type	9/125 μ m SMF (Single Mode Fiber)	
	Light transmission power	Class B+ +1.5~+5dBm	Class C+ +3~+7dBm
	Receiving sensitivity	Class B+ -28dBm	Class C+ -30dBm
	Saturation power	Class B+ -8dBm	Class C+ -12dBm
Network management method		Support CLI、SNMP、TELNET、SSH、WEB	
Business capabilities		<p>Support device log, device upgrade, device management, condition monitoring, configuration management, and user management.</p> <p>Layer 2 switching configuration management: Like port management, VLAN, RSTP, IGMP, ACL, QOS and so on.</p> <p>PON function configuration management: Like OLT authentication, DBA template, service template, line template and so on.</p>	
Backplane Bandwidth		136G	
Size		440mm(L)*391mm(W)*44mm(H)	
Weight		4kg	
Power supply	220VAC	AC: 90V~240V, 47/63Hz	
	-48DC	DC:-36V~-72V	
Maximum power		70W	
Working environment	Working temperature	0~50 $^{\circ}$ C	
	Storage temperature	-40~85 $^{\circ}$ C	
	Relative humidity	5~90% (Non-condensing)	